



Color Variants

VL200120
Black control panel
Width 15 cm

Optional accessories

LS041001
Ventilation moulding for VL 200 next to gas appliance

Installation Accessories

VV200010
Stainless steel connection strip for combination with other Vario appliances of the 200 series
VV200020
Black connection strip for combination with other Vario appliances of the 200 series

VL200120

Vario downdraft ventilation 200 series
Black control panel
Width 15 cm
Air extraction / Air recirculation
Motorless

Can be combined with the cooktops of the Vario 200 series to a harmonic unity
Highly efficient ventilation system at the cooktop integrated in the worktop
Function for automatic, sensor-controlled power adjustment depending on the build-up of cooking vapours
Minimal planning and easy installation
Low-noise system with the motor AR 410 110
Air extraction or air recirculation system

Output

Power levels depend on the remote fan unit, see table on page XX.

Features

Control knobs with illuminated ring.
3 electronically controlled power levels and 1 intensive mode.
Automatic function with sensor-controlled run-on function.
Large-scale metal grease filter with high grease absorption.
Grease filter, dishwasher-safe.
Grease filter and activated charcoal filter saturation indicator.
Airflow-optimised interior for efficient air circulation.
Interval ventilation, 6 min.
Enamelled ventilation grille, dishwasher-safe.
Air exhaust bend included in delivery.
Overflow 250 ml capacity.

Consumption data

Consumption data is referred to a configuration with the remote fan unit AR 403 122.
Energy efficiency class A+ at a range of energy efficiency classes from A++ to E.
Energy consumption 37 kwh/year.
Ventilation efficiency class A.
Illumination efficiency class -.
Grease filter efficiency class B.
Sound level min. 56 dB / max. 71 dB normal mode.

Planning notes

Air recirculation mode in combination with remote fan unit with AR 410 110 or AR 413 122.
Air extraction in combination with remote fan unit AR 400 142, AR 401 142 or AR 403 122.
Please refer to page XX for recommended configurations of downdraft ventilations and remote fan units and the needed ducting elements.
For each VL one remote fan unit is recommended.
Maximum cooktop width between 2 VL: 60 cm.
If installed next to gas appliances, the ventilation moulding LS 041 001 is recommended to ensure maximum performance of the cooktop.
When having installed the ventilation moulding LS 041 001 the wok pan WP 400 001 can not be used.
When installing a ventilation hood with air extraction mode and a chimney-vented fireplace, the power supply line of the ventilation appliance needs a suitable safety switch.
Please read additional planning notes on page xx.

Connection

Characteristics

Product name/family
Color chimney
Typology
Approval certificates
Australia Standards, CE, Eurasian, G-Mark, VDE
Length electrical supply cord (cm)
170
Required niche size for installation (HxWxD)
175mm x 170mm x 492mm
Height of the chimney (mm)
Height of product, without chimney (mm)
Net weight (kg)
4.351
Type of control
Electronic
Number of speed settings
Maximum output air extraction (m3/h)
600
Boost position output recirculating (m3/h)
Maximum output recirculating air (m3/h)
Boost position air extraction (m³/h)
Number of lights
Noise level (dB)
71
Diameter of air outlet (mm)
Grease filter material
Odour filter
No
Operating Mode
Convertible
Delay Shut off modes
Required accessories
Blower
Optional accessories
LS041001
Type of lamps used
Total power of the lamps (W)
Grease filter type
Kassette
Clean filter reminders

Consumption and connection features
Connection Rating (W)
Current (A)
Voltage (V)
Frequency (Hz)
60; 50
Plug type
Installation typology
Built-in
Universal Product Code
825225951148
Material body
Alu
Approval certificates
Australia Standards, CE, Eurasian, G-Mark, VDE
Length of electrical supply cord (in)
Plug type
Dimensions of the product, with chimney (if exists) (in)
/ x 5 7/8" x
Dimensions of the packed product (in)
11.61 x 15.55 x 23.62
Height of the chimney (in)
Vertical rise height
Required distance above cooktop/ranges
Net weight (lbs)
10
Gross weight (lbs)
15
Motor location
without motor
Maximum output recirculating air (CFM)
Diameter of air duct (in) top
Diameter of air duct (in) back
Discharge direction
downward
No-return airflow flap
No
Length electrical supply cord (cm)
170
Dimensions of the product. with

Connecting cable 1.7 m between VL and remote fan unit.

VL200120
 Vario downdraft ventilation 200 series
 Black control panel
 Width 15 cm
 Air extraction / Air recirculation
 Motorless
 2019-05-20
 Page 2

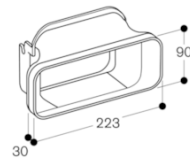
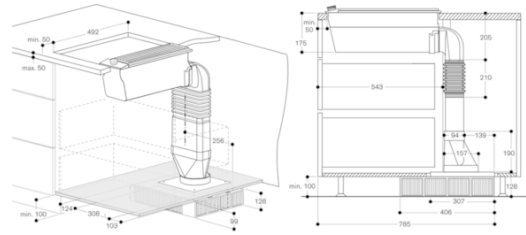
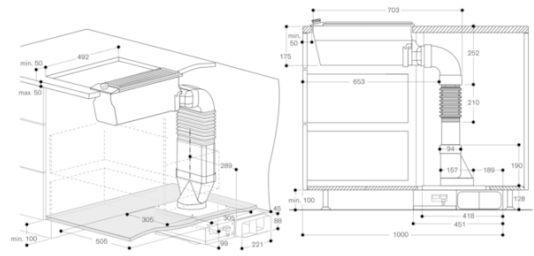
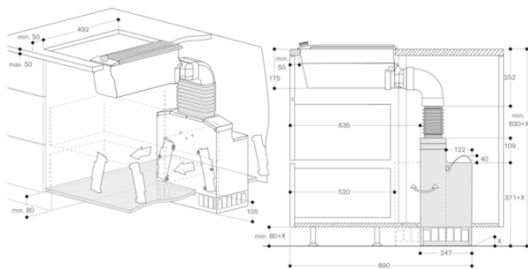
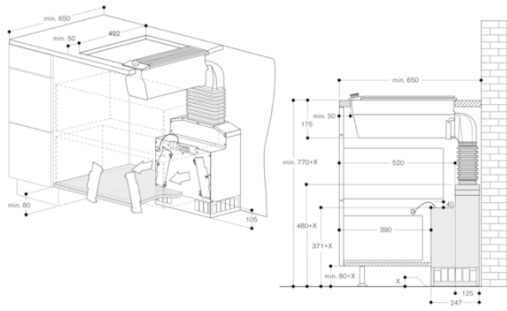
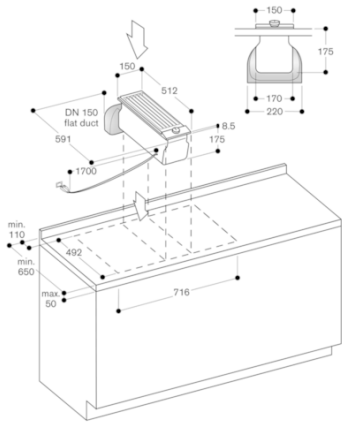

VL200120
Vario downdraft ventilation 200 series
Black control panel
Width 15 cm
Air extraction / Air recirculation
Motorless
2019-05-20
Page 3

