



Color Variants

VG415111F
Stainless steel
Width 38 cm

Included accessories

1 x WOK attachment ring.

Optional accessories

WP400001
Wok pan made of multiple-layer material

Installation Accessories

VA420000
Connection strip for combination with other Vario appliances of the 400 series for flush installation
VA420010
Connection strip for combination with other Vario appliances of the 400 series for surface installation
VA440010
Stainless steel appliance cover with mounting strip

VG415111F

Vario gas wok 400 series

Stainless steel

Width 38 cm

Liquid gas 28 - 37 mbar

Wok burner with 5.8 KW

Multi-ring burner with 5.8 KW
Full electronic power level regulation on 12 levels
Precise and reproducible flame size
Automatic fast ignition, electronic flame monitoring with automatic re-ignition
Simmer function for cooking on a very low output level
Solid stainless steel control knob
Precision crafting of 3 mm stainless steel
For surface installation with a visible edge or for flush installation
Can be combined perfectly with other Vario appliances of the 400 series

Cooking zones

1 multi-ring wok burner (300 W – 5800 W), suitable for pots up to max. ø 32 cm.

Handling

Control knobs with illuminated ring, cooking zone and output level markings.
One-handed operation.
Full electronic control in 12 output levels for exact power level adjustment plus simmer function.
Automatic fast ignition.

Features

Simmer function.
Cast pan support with flat, continuous pot surface.
Brass burner rings.

Safety

Electronic flame monitoring with automatic re-ignition.
Residual heat indication.
Safety shut-off.

Planning notes

Depending on the type of installation (surface-mounted or flush-mounted, with or without an appliance cover), the specific location of the cut-out and the knob positions may vary.
The drawing "Installation of the control knob" must be observed if the panel is more than 23 mm thick (there must be a recess at the rear).
If installing with the appliance cover VA 440 or adjustment strip VA 450 take into account the additional space required for the depth.
If combining several appliances with at least one appliance cover, the adjustment strip VA 450 is required to compensate for the depth of the appliance without the appliance cover.
If combining several Vario appliances of the 400 series, a connection strip VA 420 must be placed between the appliances. Depending on the type of installation, the corresponding connection strip must be provided.
In the cut-out, the installation system requires the side edge to be at least 10 mm for surface installation and at least 13 mm for flush installation. Ensure a continuous cut surface of 90°.
The bearing capacity and stability, in the case of thin worktops in particular, must be supported using suitable substructures. Take into account the appliance weight and additional loads.
Additional instructions for flush installation:

Characteristics

Product name/family

Vario/Domino gas hob

Built-in / Free-standing

CONSTR_TYPE.Built-in

Energy input

Gas

Total number of positions that can be used at the same time
1

Required niche size for installation (HxWxD)

134 x 360 x 492

Width of the product (mm)

380

Dimensions of the product (mm)

134 x 380 x 520

Dimensions of the packed product (HxWxD) (mm)

300 x 500 x 600

Net weight (kg)

15.354

Gross weight (kg)

17.4

Residual heat indicator

Location of control panel

External control

Basic surface material

brushed stainless steel

Color of surface

Stainless steel, Stainless steel

Color of frame

Stainless steel, Stainless steel

Approval certificates

CE, Eurasian, G-Mark, VDE

Length of electrical supply cord (cm)

140

EAN code

4242006261252

Consumption and connection features

Electrical connection rating (W)

15

Gas connection rating (W)

5800

Current (A)

2

Voltage (V)

220-240

Frequency (Hz)

50; 60

created on 2020-03-31

Page 1

Installation is possible in worktops made of stone, synthetics or solid wood. Heat resistance and watertight sealing of the cut edges must be observed. Concerning other materials please consult the worktop manufacturer.

The groove must be continuous and even, so that uniform placing of the appliance on the gasket is ensured. Do not use discontinuous lining.

The joint width may vary due to size tolerances of the combinations and of the worktop cut-out.

If installing several appliances in individual cut-outs allow for a division bar of minimum 50 mm between the individual cut-outs.

Special nozzles can be ordered as spare parts.

Plan for an electrical connection (the appliance is not operable without power supply).

Air intake from above.

No intermediate shelf required.

Rear panel and wall trims must be heat-resistant and consist of a non-flammable material.

A minimum clearance of at least 150 mm from adjacent heat-sensitive furniture or contact surfaces must be observed or thermal insulation fitted.

If operated next to the downdraft ventilation VL 414, the air baffle AA 414 is recommended to ensure maximum performance of the cooktop.

With a total connected load of more than 12 kW local regulations concerning room ventilation, room size and combination of extraction or recirculation hoods must be observed.

Minimum clearance between gas cooktop(s) with more than 12 kW and ventilation hood 70 cm.

Appliance can be snapped into the worktop from above.

Appliance weight: approx. 15 kg.

Connection

Total connected load gas 5.8 kW.

Total connected load electric 15.0 W.

Connecting cable 1.4 m with plug.

VG415111F
 Vario gas wok 400 series
 Stainless steel
 Width 38 cm
 Liquid gas 28 - 37 mbar
 Wok burner with 5.8 KW

created on 2020-03-31
 Page 2

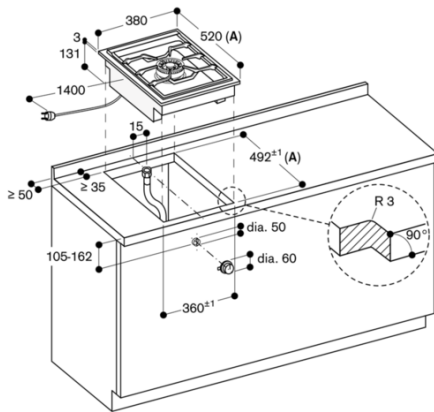

A: When installing with appliance cover, take the deeper cut-out into consideration (observe separate planning notes)

measurements in mm

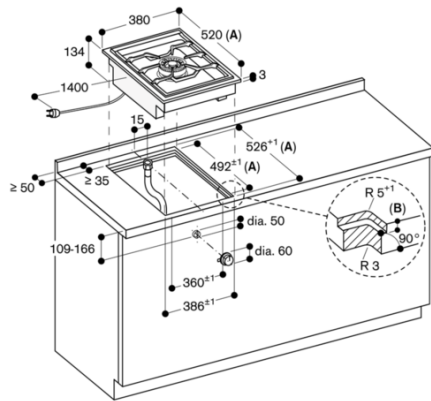

A: When installing with appliance cover, take the deeper cut-out into consideration (observe separate planning notes)
 B: 3.5^{±1}

measurements in mm

Installation with appliance cover, flush mounting

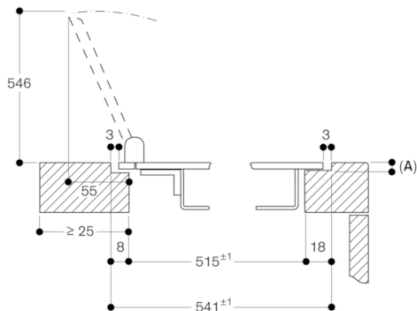

A: 3.5^{±0.5}

measurements in mm

Installation with appliance cover, surface mounting

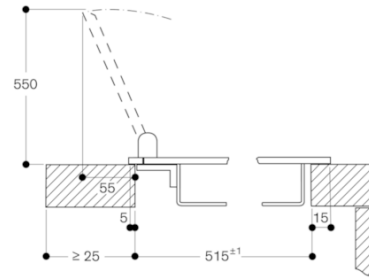

measurements in mm

Cross-section

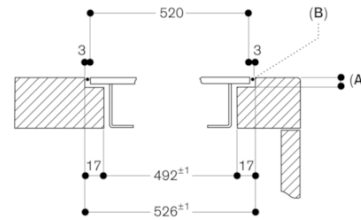

A: 3.5^{±0.5}
 B: Fill with silicone

When installing with appliance cover, pay attention to the deeper cut-out and the front and rear groove width.

measurements in mm

Installation with appliance cover, surface mounting

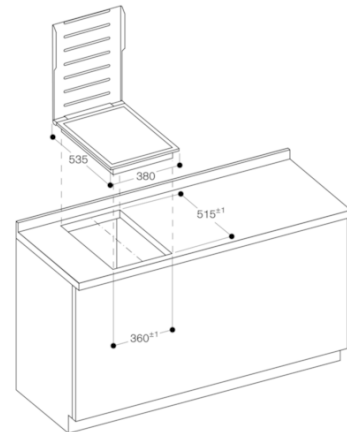

measurements in mm

VG415111F

Vario gas wok 400 series

Stainless steel

Width 38 cm

Liquid gas 28 - 37 mbar

Wok burner with 5.8 KW

created on 2020-03-31

Page 3

View from above

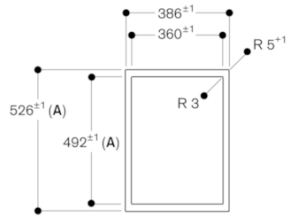

A: When installing with appliance cover, take the deeper cut-out into consideration (observe separate planning notes)

measurements in mm

Longitudinal section

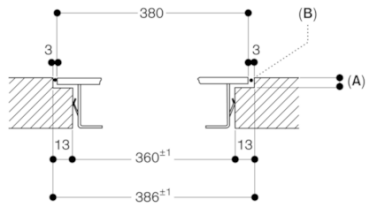

A: 3.5^{±0.5}

B: Fill with silicone

measurements in mm

Installation with appliance cover, flush mounting

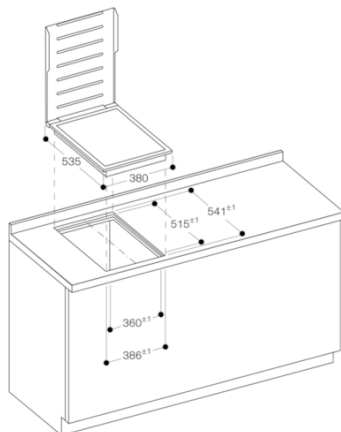

measurements in mm

GAGGENAU